

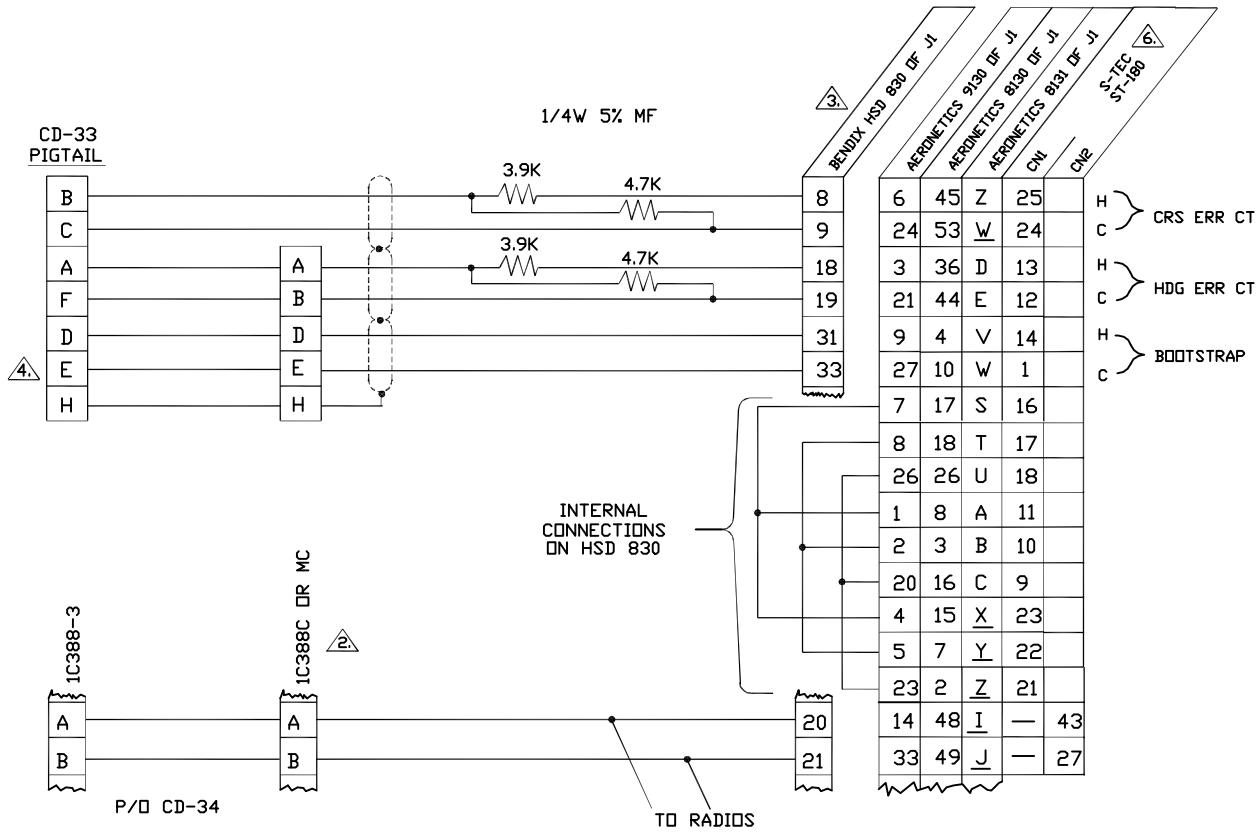

REVISIONS			
LTR	DESCRIPTION	DATE	APPROVED
-	REL PER E.D. 13376	1-10-90	JJK
A	REV PER E.D. 16512	9-9-97	LMH
B	REV PER E.D. 16720	3-13-98	S.C.



- NOTES:
1. BOOTSTRAP OUTPUT CAN NOT BE USED TO DRIVE RMI WITH THIS INSTALLATION.
 2. 1C388C NOT RECOMMENDED, IF USED BOTH HEADING BUG AND COURSE ARROW MUST BE SET TO RADIO CRS AND INSTRUCTIONS TO THIS EFFECT MUST BE IN AIRCRAFT.
 3. I.N. 831 P/N 4000172-8505 VERSION ONLY, BENDIX SL74-005 AND FIG. 5-2 (SH 2) OF BENDIX I.B. 2831A REFER.
 4. IF HDG AND CRS SHOW REVERSE RESPONSE EXCHANGE WIRES ON PINS D AND E.
 5. NOT APPLICABLE TO 1C388-2.
 6. BOOTSTRAP #1 OUTPUT CAN NOT BE USED TO DRIVE RMI WITH S-TEC ST-180 INSTALLATION.

		DRAWN M USWALD	J.N. PURITT 1-9-90 9-9-97	 <p>BOX 610, MUNICIPAL AIRPORT FLIGHT SYSTEMS, INC. MINERAL WELLS TX, 76067</p>
		CHECKED	S. COLLINS 1-9-90	
		ENGINEER	HIGGINS 1-9-90	
		APPROVED	J.J.K. 1-12-90	
		FILE:	63C778.dwg	
		THIS DRAWING IS THE PROPERTY OF CENTURY FLIGHT SYSTEMS INC. ITS POSSESSION BY UNAUTHORIZED PERSONS SHALL NOT BE CONSTRUED AS PERMISSION TO REPRODUCE FOR SALE, IN WHOLE OR IN PART, ANY DEVICES SHOWN THEREIN.		
	NEXT ASSY	USED ON	APPLICATION	TITLE C II & III WIRING INTERCONNECT SUPPLEMENT FOR HSI'S WITH INTERNAL BOOTSTRAP
		SIZE C	DWG NO. 63C778	REV B
		SCALE N/A	H:\USERS\DRAWING\SIZE_C	SHEET 1 OF 1